

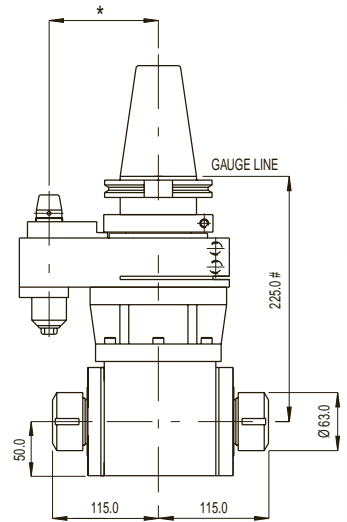

RAD 225 D

RIGHT ANGLE MILL/DRILL/TAP DOUBLE ENDED

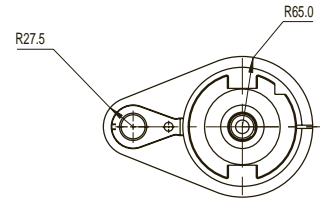
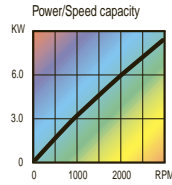

Max. speed	3,000 rpm
Max. tool shank dia.	30 mm / 1.3/16"
Max. tapping size	M22 / 7/8"
Ratio	1:1
Rotation	Opposite
Drive taper	50 BT-CT-DIN-HSK
Tool holding	Collet chuck ER40
Max. weight without tooling	17.5 kg / 39 lbs

The Double Ended RAD-225 is able to accommodate end mills, drills and tension tap collets.

- Auto tool change capability
- Alternative drive tapers available
- Maintenance free sealed unit

228 mm with BT

* Pin centre distance to suit application