

## UAH 140

### UNIVERSAL ANGLE HEAD

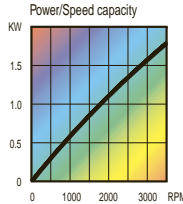

- Auto tool change capability
  - Alternative drive tapers available
  - Maintenance free sealed unit
- \* Pin centre distance to suit application

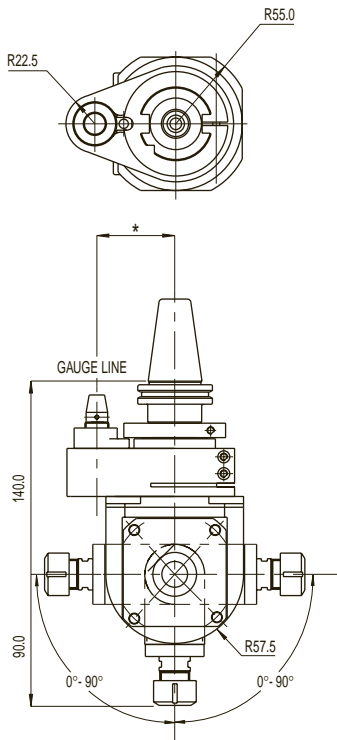

Max. speed	3,500 rpm
Max. tool capacity	Ø 10.0 mm / 3/8"
Ratio	1:1
Rotation	Same
Drive taper	30/40 BT-CT-DIN-HSK
Tool holding	Collet chuck ER16
Max. weight without tooling	6.0 kg / 14 lbs

## UAH 180

### UNIVERSAL ANGLE HEAD

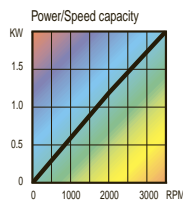
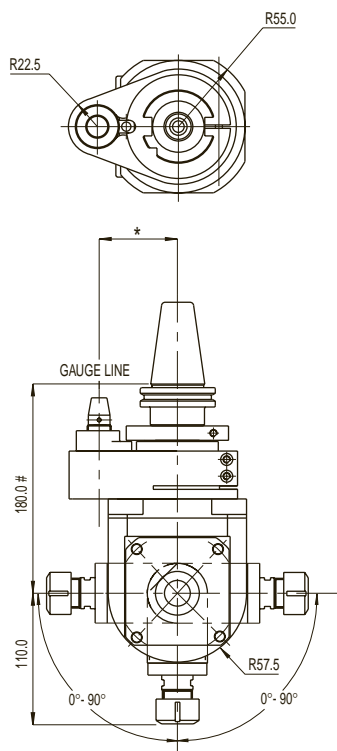

- Auto tool change capability
  - Alternative drive tapers available
  - Maintenance free sealed unit
- # 183 mm with 50BT  
 \* Pin centre distance to suit application



Max. speed	3,500 rpm
Max. tool capacity	Ø 13.0 mm / 1/2"
Ratio	1:1
Rotation	Same
Drive taper	40/50 BT-CT-DIN-HSK
Tool holding	Collet chuck ER20
Max. weight without tooling	8.0 kg / 18 lbs